

PB10E/S

PB10E/D

AZIONAMENTO ELETTRICO

ELECTRIC DRIVEN

ACCIONAMIENTO ELECTRICO

ACTIONNEMENT ELECTRIQUE



MACCHINE ESTRUSIONE SOFFIAGGIO FINO A 10 LITRI

EXTRUSION BLOW MOULDING MACHINES UP TO 10 LITRES

MAQUINAS DE EXTRUSION SOPLADO HASTA 10 LITROS

MACHINES D'EXTRUSION SOUFFLAGE JUSQU'A 10 LITRES

plastiblow****
EXTRUSION BLOW MOULDING

Dati generali / General data / Datos generales / Données générales		PB10E/S	PB10E/SL	PB10E/SXL	PB10E/SXXL	PB10E/D	PB10E/DL	PB10E/DXL	PB10E/DXXL
Stampi / Moulds / Moldes / Moules	n°	1	1	1	1	2	2	2	2
Corsa / Stroke / Carrera / Course	mm	500	630	800	1200	500	630	800	1200
Ciclo a vuoto / Dry cycle time / Ciclo en vacío / Cadence à vide	s	2,4	2,8	2,9	3,4	2,7	2,8	2,9	3,4
Forza di chiusura / Mould clamping force / Fuerza de cierre / Force de fermeture	kN	220							

Consumi / Consumption / Consumos / Consommation		PB10/S				PB10/D			
Pressione aria / Air pressure / Presión aire / Pression air	bar	6 + 8							
Consumo aria / Air consumption / Consumo aire / Consommation air	Nl/min	1500				3000			
Pressione acqua / Cooling water pressure / Presión agua / Pression eau	bar	3 + 5							
Raffreddamento stampi / Mould cooling / Enfriamiento moldes / Refroidissement moules	kJ/kg	650 (HDPE)							

Estrusore / Extruder / Extrusora / Extrudeuse		E70/25	E80/25	E90/25	E100/25	E120/28
Diametro vite / Screw diameter / Diámetro husillo / Diamètre vis	mm	70	80	90	100	100
Lunghezza vite / Screw length / Largo husillo / Longueur vis	L/D	25	25	25	25	28
Potenza motore / Motor power / Potencia motor / Puissance moteur	kW	37	45	59	88	113
Potenza di riscaldamento / Heating power / Potencia de calefacción / Puissance de chauffage	kW	12	15,2	20	21	22
Zone di riscaldamento / Heating zones / Zonas de calefacción / Zones de chauffage	n°	4	4	5	6	6
Ventilatori / Cooling fans / Ventiladores / Ventilateurs	n°	4	4	4	5	5
Plastificazione HDPE / HDPE plasticizing / Plastificación con HDPE / Plastification HDPE	kg/h	110	150	190	250	300
Plastificazione PVC / PVC plasticizing / Plastificación con PVC / Plastification PVC	kg/h	70	85	110	-	-

Teste d'estrusione / Extrusion heads / Cabezales de extrusión / Têtes d'extrusion		T1V	T2V	T3V	T4V	T6V	T8	T10V
Uscite / Outlets / Salidas / Sorties	n°	1	2	3	4	6	8	10
Volume contenitore / Container volume / Volumen envase / Volume flacon	l	10	6	5	3,5	2	1,2	1
Zone di riscaldamento / Heating zones / Zonas de calefacción / Zones de chauffage	n°	5	9	12	17	23	31	37
Interasse uscite / Center distance / Distancia entre centros / Entraxe filières	mm	-	140-300	100-240	70-180	70-150	70-140	70-110
Diametro filiera / Die diameter / Diámetro hilera / Diamètre filière	mm	100+140	80+100	53+80	33+53	33+53	33+53	33+53

Stampo / Mould / Molde / Moule		PB10E/S	PB10E/SL	PB10E/SXL	PB10E/SXXL	PB10E/D	PB10E/DL	PB10E/DXL	PB10E/DXXL
A	mm	520	650	820	1220	490	620	790	1190
B	mm	128 + 135							
C	mm	270							
H	mm	470	470	420	420	470	470	420	420

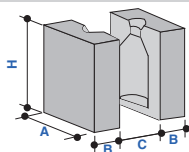

CARRO SINGOLO / SINGLE STATION / ESTACION SIMPLE / CHARIOT SIMPLE

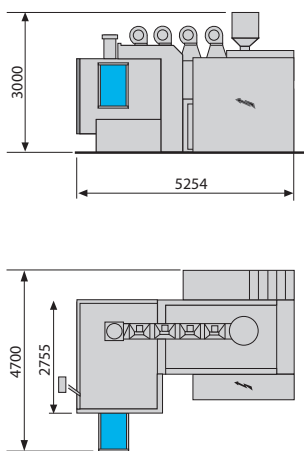

Peso / Weight / Peso / Poids (E90/25) 6.400 kg

CARRO DOPPIO / DOUBLE STATION / ESTACION DOBLE / CHARIOT DOUBLE

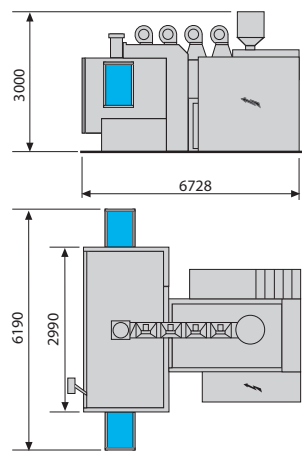

Peso / Weight / Peso / Poids (E90/25) 15.200 kg